

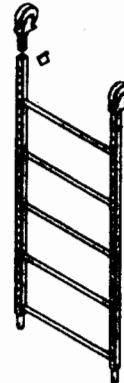

Snappy

Assembly Instructions

- 1) Turn the end frames upside down and insert the casters into the frame legs. Pin the casters in place with 2" snap pins.



- 2) (A) Turn the frames right side up and engage the lock on the casters. While holding one end frame with one hand (or lean it against a wall) use your other hand to pull back the "G" pin on the arm brace and engage the "U" channel over the frame leg. (B) Then release the "G" pin and slide the arm brace up or down on the frame leg until the pin snaps into a hole. Repeat for the opposite end of the brace and second end frame.

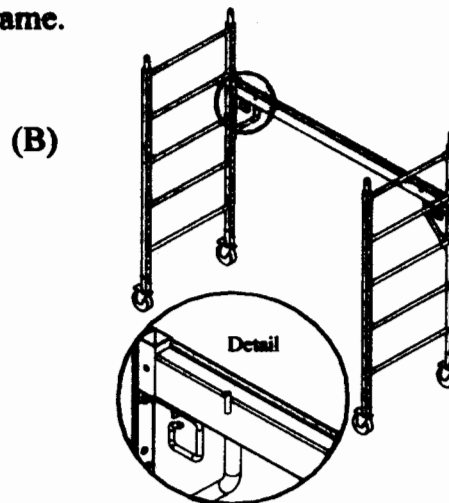
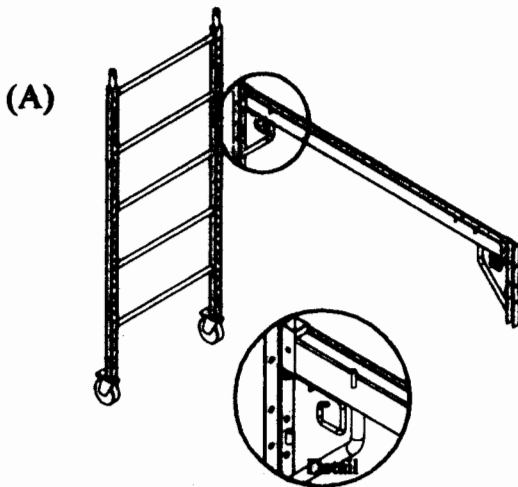

- 3) Attach the second arm brace as described in step 2. Make sure both arm braces are positioned at the same level. Be sure the platform hold down devices are turned out of the way.

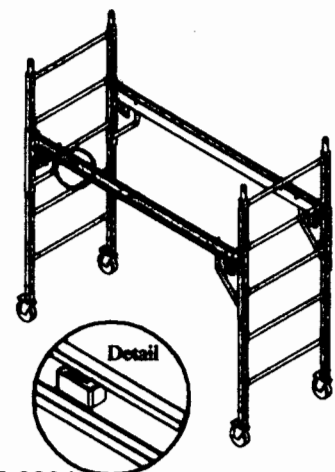

Granite
Industries

ph: 419-445-4733 • toll free: 877-4GRANITE • fax: 419-445-3304
595 E. Lugbill Road • P.O. Box 408 • Archbold, OH 43502
e-mail: info@graniteind.com

- 4) (A) Then lay a plywood platform on the braces. Line up the 4 holes in the plywood with the pins on the arm braces. (B) Turn the platform hold down devices so that they "trap" the platform onto the braces.

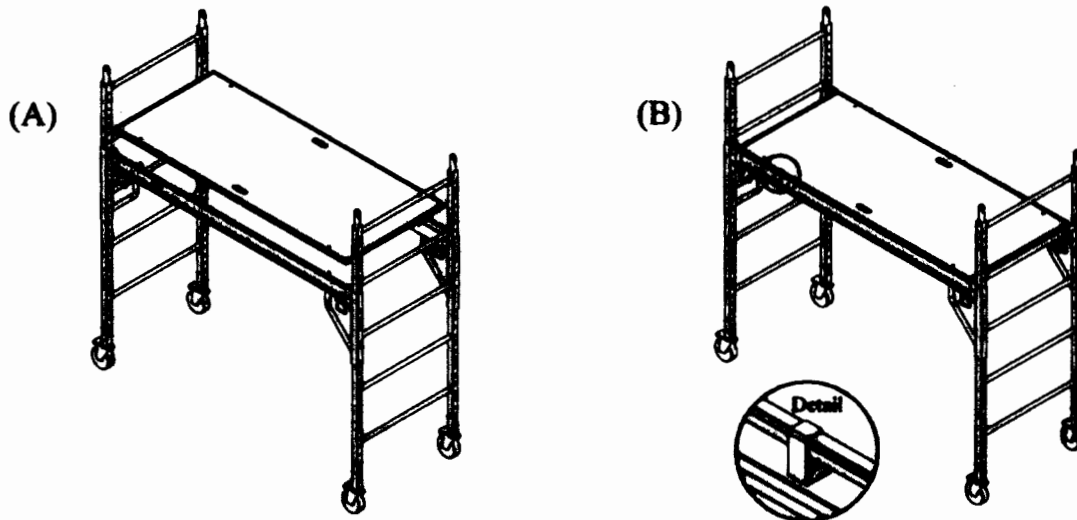

- 5) The platform height can now be easily adjusted. By standing at the end of the unit, disengage a "G" pin with each hand. The arm braces and platform can now be moved up or down on the frame. When at the preferred height, release the "G" pins and move the platform up or down until the "G" pins snap into the nearest hole. Adjust the opposite end in the same way.

- 6) For additional security insert 2" snap pins through the "U" channel and frames after the platform height has been properly set.

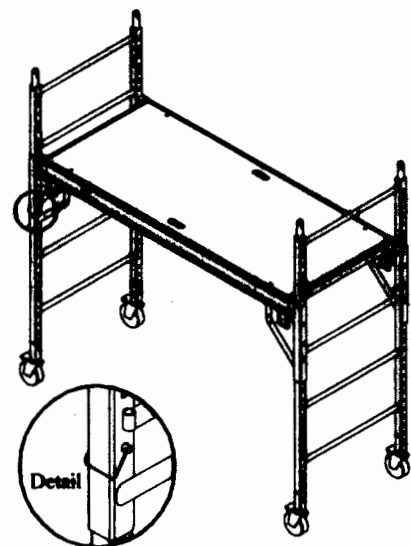

1ST
FIRST PLACE RENTAL
4975 Route 71 Oswego, IL 60543
630-554-3155
www.firstplacental.com